

REV.	PART No.	PART NAME	MATERIAL	TYPE	Q'TY	REMARKS
	100	ミラー	PC	耐衝撃性	1	
	101	両面テープ	アクリル系接着剤		1	
	102	裏板	AL	A1100P	1	
	103	接着剤	シリコ変性ポリマー		1	
	104	接着剤	シリコ変性ポリマー		1	
	(K) 204	F15B用アルミ枠	AL		1	
	300	両面テープ	アクリル系接着剤		4	
	400	ロゴシール			1	
	500	皿頭タッピングビス	SUS	4×30	4	付属品
	501	ナイロンプラグ			4	付属品

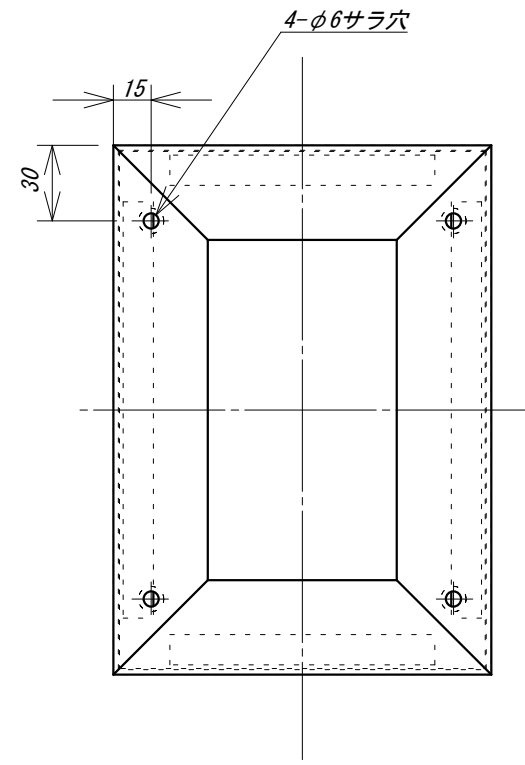
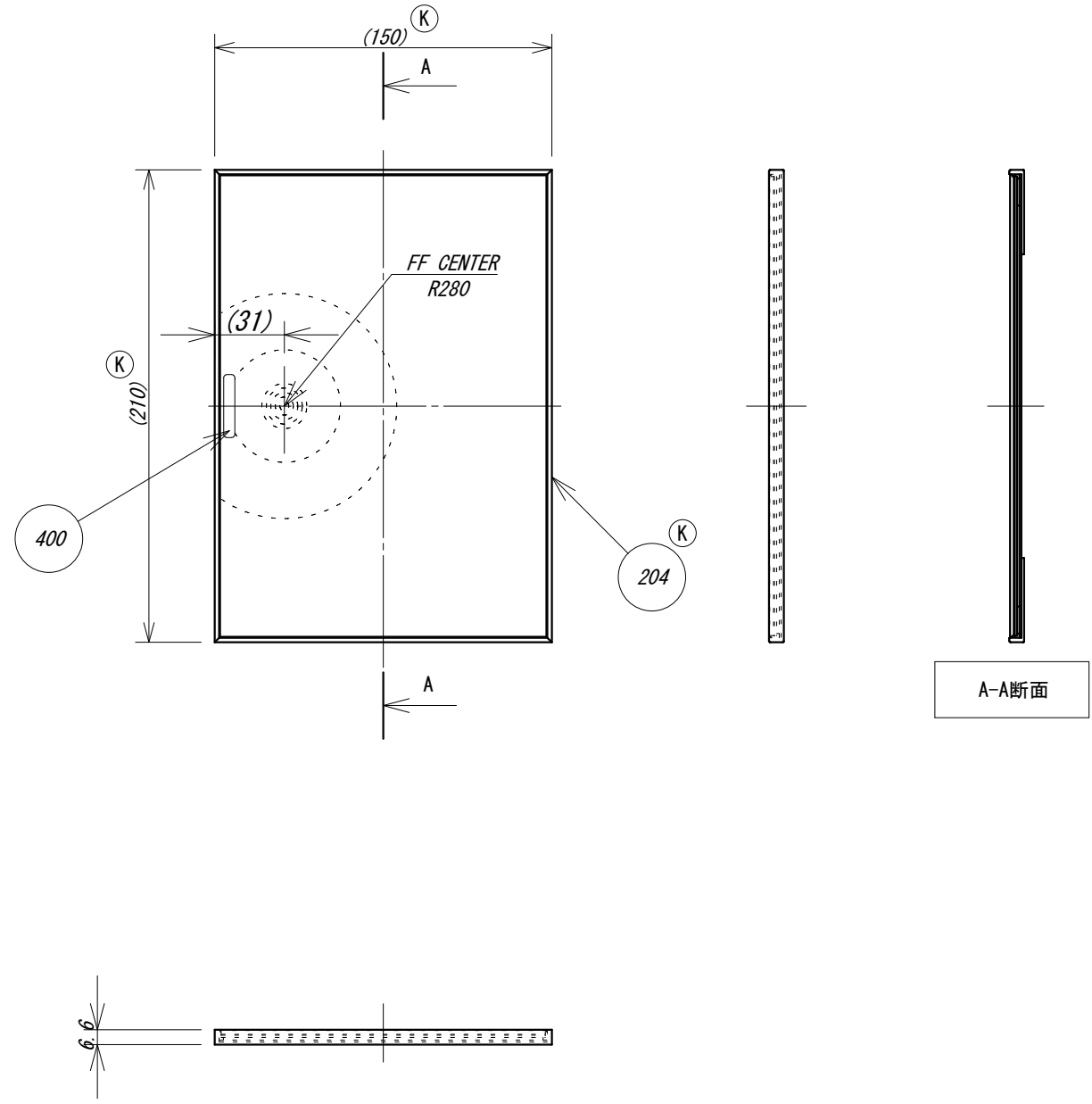

A-A断面

(K) Nov-01-16	アルミ枠変更	S. FUNADA	T. YOKOTA	T. TAMURA	TITLE FFミラー車出口 (F15B)	PROJECTION SCALE A3 DIM. 1:3 mm	ASS. WEIGHT (Max0.30kg)	DRW. No. F15B	REV. SYM. K
(J) Sep-05-16	端面処理及び裏板変更	S. FUNADA	T. YOKOTA	T. TAMURA					
(I) Apr-22-15	焦点位置及び両面テープ配置変更	T. HASEGAWA	H. TAKEDA	T. TAMURA					
(H) Dec-05-14	端面処理変更	T. YOKOTA	H. TAKEDA	T. TAMURA					
REV. SYM.	DATE	DESCRIPTION	DWG.	CHKD.	APRD.	CUSTOMER	DWG. K. IWAMI Oct-20-00	CHKD. T. TAMURA Oct-20-00	APRD. Y. KOYAMA Oct-20-00